

TremLock® VP 3"

Standing Seam Metal Roof System

FEATURES

- Factory applied rib sealant
- Versatile

BENEFITS

- Ensures water tightness
- Can be used as a roof or wall panel



DESCRIPTION

TremLock VP 3" Roof System is a factory roll formed metal roof / wall system that is manufactured from 24 or 22 gauge Galvalume®, an aluminum-zinc alloy meeting ASTM A792, Class AZ-50. The galvanized panel is coated with Kynar 500® / Hylar 5000®. Rib sealant is installed at the factory to ensure water tightness.

BASIC USES

The TremLock VP 3" Metal Roof System can be specified as a new or retrofit system for Architectural application on roof slope minimum 1/4:12. Its versatile structural standing seam design and aesthetically pleasing appearance make it suitable for almost any roof configuration and complex geometrics. They are capable of spanning secondary structural members spaced up to five feet and can be applied to light gauge steel framing or 5/8" minimum plywood decks. Continuous lengths up to 80'.

SYSTEM DESIGN

TremLock VP 3" Roof System is designed with a 3" leg height that requires mechanical field seaming. TremLock VP 3" Roof System can be installed over a wide variety of substrates capable of spanning secondary structural members spaced up to five feet and can be applied to light gauge steel framing, 5/8" minimum plywood decks, metal deck and rigid insulation or open framing..

FINISH/COLOR

Acrylic Coated Galvalume®
 Fluoropolymer (Kynar 500® PVDF resin-based).
 Oil canning is inherent in all metal panels and is not cause for panel rejection

APPLICATION

Refer to TremLock VP Installation Manual.

SECTION PROPERTIES & PROFILES

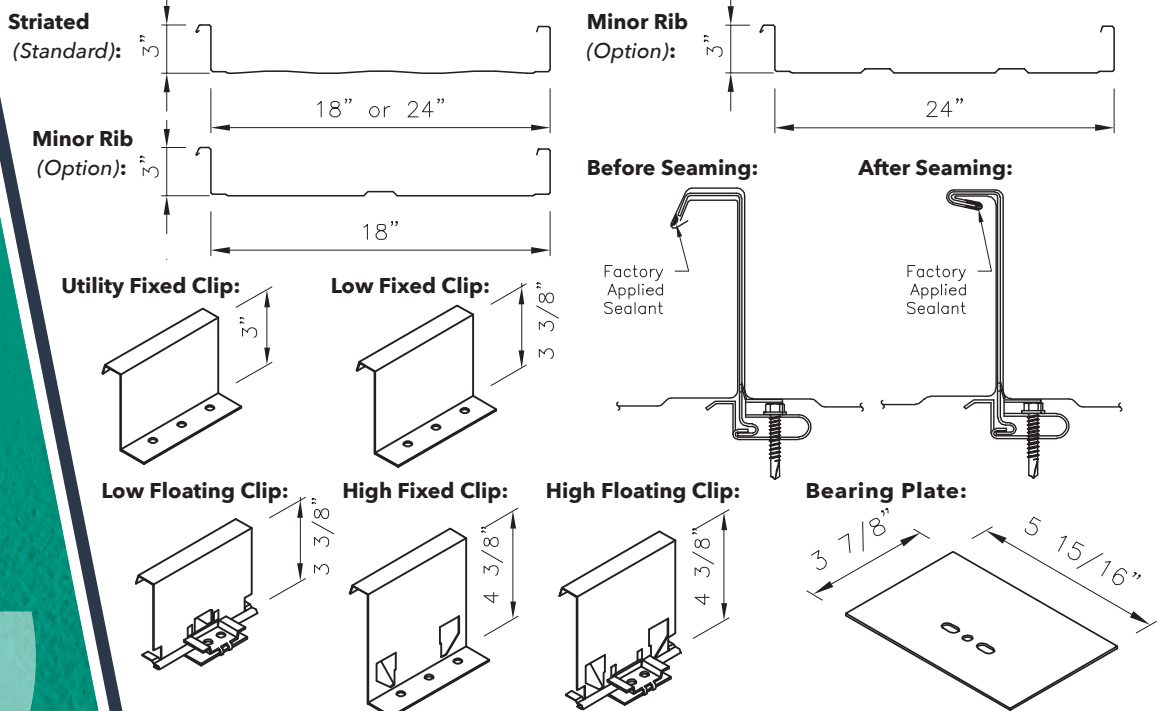

**SECTION PROPERTIES
& PROFILES**
CONTINUED

TremLock® VP 3"

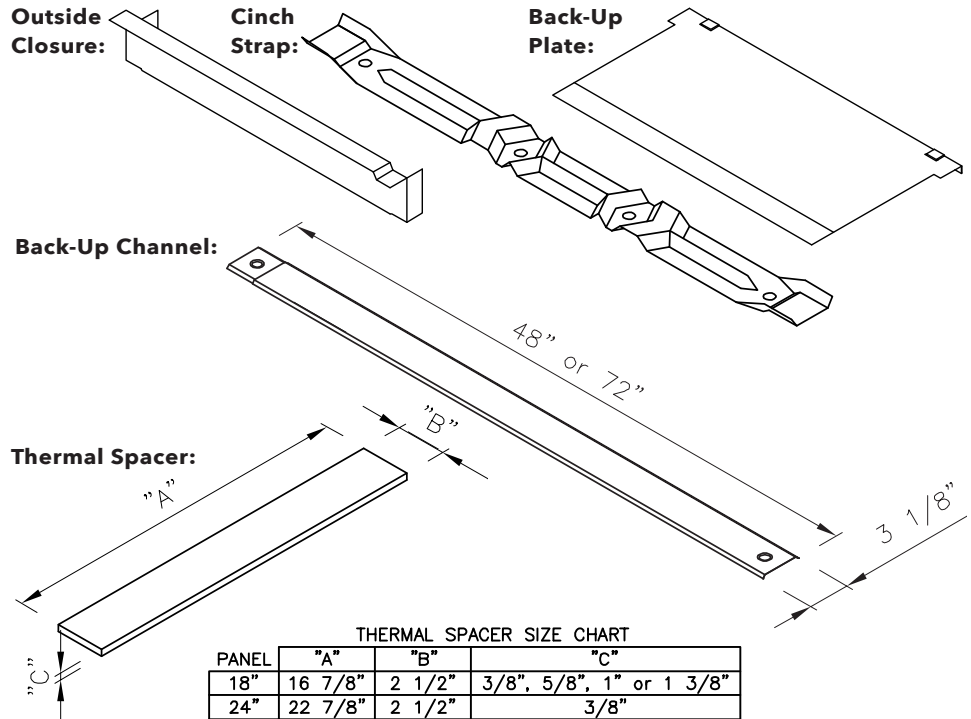

PHYSICAL PROPERTIES

TITLE OF TEST	TEST METHOD
Uplift Test	UL 580 Class 90, ASTM E1592
Air & Water Infiltration	ASTM E1680, ASTM E1646
Impact Resistance	UL 2218 Class 4
Florida State Approval	FL 1832.4
Fire Resistance	UL 263 & UL 790 Class A
FM	4471 (1-90 Rated) (TremLock 318 only)
ICC-ES Approval	ESL-1082

All testing conducted with a Galvalume® substrate.

MAINTENANCE

Your local Tremco Roofing Sales Representative can provide you with effective maintenance procedures which may vary, depending upon specific conditions. Periodic inspections, early repairs and preventative maintenance are all part of a sound roof program.

PRECAUTIONS

Users must read container labels and Safety Data Sheets for health and safety precautions prior to use.

TECHNICAL SUPPORT

Your local Tremco Roofing Sales Representative, working with the Technical Service Staff, can help analyze conditions and needs to develop recommendations for special applications.



www.tremcoroofing.com
3735 Green Road
Beachwood, Ohio 44122
1.800.852.6013

220 Wicksteed Avenue
Toronto, Ontario, M4H 1G7
1.800.668.9879

Tremco Roofing and Building Maintenance is part of Tremco Construction Products Group.

Tremco is a US Registered trademark of Tremco CPG Inc.
The information provided on this data page supersedes all previous data concerning this product and its application.
The Statements provided concerning the materials shown are intended solely as a general guide for material usage and are believed to be true and accurate. Since the manner of use is beyond our control, Tremco DOES NOT MAKE NOR DOES IT AUTHORIZE ANY WARRANTY OF MERCHANTABILITY OR FITNESS FOR ANY PURPOSE, OR ANY OTHER WARRANTY, GUARANTEE OR REPRESENTATION, EXPRESSED OR IMPLIED, CONCERNING THIS MATERIAL EXCEPT THAT IT CONFORMS TO TREMCO'S PRODUCT SAMPLE. Buyer and user accept the product under those conditions and assume the risk of any failure, injury of person or property and loss or liability resulting from the handling, storage or use of the product, whether or not it is handled, stored, used in accordance with directions or specifications. UNDER NO CIRCUMSTANCE SHALL TREMCO BE LIABLE FOR CONSEQUENTIAL OR INCIDENTAL DAMAGES ARISING FROM ANY BREACH OF WARRANTY. IN ALL CASES, TREMCO'S LIABILITY IS LIMITED, AT TREMCO'S OPTION, TO THE REPLACEMENT OF GOODS, OR THEIR VALUE, PROVEN TO BE DEFECTIVE IN MANUFACTURING.
TremLock® is a U.S. registered trademark of Tremco CPG Inc.
Kynar 500® is a U.S. registered trademark of Arkema Inc.
Hylar 5000® is a U.S. registered trademark of Solvay Solexis, Inc.
Galvalume® is a U.S. registered trademark of BIEC International Inc.
Fluoropon® is a U.S. registered trademark of SWIMC LLC.